

FRC Global Product Lines





Expert Teams.



Quality Products.



Global Networks.

Who We Are

FRC Global is a leader in the supply of refractories, electrodes, and high-temperature combustion systems.

Supplying the iron, steel, and non-ferrous metals industries for over three decades, our reputation has been built upon being problem solvers for our customers. We are constantly looking for new ways to maximize output, increase efficiency, and positively impact your bottom line.

Our commitment goes beyond providing premium raw materials; we are dedicated to offering unparalleled technical support from our team of seasoned engineers.

We take pride in being more than just a supplier, and we believe your success is a direct reflection of our genuine partnership.

We are constantly searching for the best raw materials from our vast global network, and have the ability to adapt nimbly to meet the demands of our changing industry. With over 25 warehouse facilities throughout the United States, Canada, Mexico, and South America we assure your products are there when you need them.

As a family-owned, American company, we are dedicated to doing our part in shaping the future of our industry for generations to come.



Our Mission

Embrace modern technology to increase innovation, efficiency, and transparency. Inspire the next generation by driving change, promoting curiosity, and shaping sustainable solutions in the high temp world.





About Us

Background Information

FRC Global is a second generation family owned company with a 30-year history.

Global Offices

FRC Global has offices, agents, or partners in 20 countries around the world.

- North America: United States and Canada
- South America: Colombia
- Asia: China

We provide quality engineered products and services for all your high temperature applications.

FRC Global facts

Our quality control employees thoroughly inspect shipments to ensure products are within specification and are properly packaged.

Sales force and service needs are available in the following:

- North America
- Central America
- South America
- Europe
- Middle East



Why FRC Global?

We show up for high-temp potential.

For over three decades, we have built strong partnerships by living up to our reputation of showing up for our customers. Our team is made up of hard-working people—many who have been in your shoes and understand the challenges you face. We are constantly thinking ahead, anticipating new barriers, and providing better solutions.

Our team knows that no two challenges are the same. When we show up to understand you and your operation, we study it to ensure we propose solutions, not just products.

As a company full of dedicated product managers and meticulous quality control teams, we travel around the

world to produce high-end products from only the best raw materials. With seasoned engineers on staff, we identify opportunities for performance and production improvements.

We are committed to excellence. Our strong relationships with global enterprises—primarily in strategic raw materials—ensure availability, performance, and consistent high quality. Our vast network serves as a cornerstone in our ability to deliver results on a global scale.

As proactive problem-solvers, we see your challenges as our own and look forward to achieving your project's greatest potential.



Ladle Refractories

Product Description

FRC Global has proven products for every ladle, slag and practice. We design well-balanced linings which provide optimal performance at the lowest possible cost. Our Apex series magnesia-carbon, and Icon magnesia-alumina-carbon brick are made from predominantly electrically fused magnesite, high purity graphite and metallic antioxidants as needed. Barrels and bottoms can be tailored to fit your operation using Apex magnesia-carbon, Oracle alumina-mag-carbon, Icon mag-alumina-carbon, or Epic fired alumina, Paragon mag-enriched dolomite and/or Durachrome magnesia-chrome brick.

Performance Highlights

We offer everything needed for your aluminum-killed and/or silicon-killed practice. Working linings are custom designed based on your specific operation. In addition to working linings, we have accessory products such as castables, plastics and ram materials, lip retaining brick systems, blocks and metal anchors. Every product is designed to provide you with optimum service in your specific operation and existing practice. FRC Global's qualified Applications Specialists will help you every step of the way.



Furnace Refractories

Product Description

We offer our Apex series magnesia-carbon for sidewalls. Apex brick are made from 100% electrically fused magnesite, high purity graphite and metallic antioxidants as needed. We can provide Durachrome magnesia-chrome brick in direct-bonded, semi-rebonded or fully-rebonded for the specialty steel manufacturers. For bottoms we offer Jehearth and Jefrit masses. For sub-hearths and stadiums we recommend Atlas burned magnesite brick with or without pitch impregnation at your discretion. Taphole sleeves, blocks, precast deltas, runner shapes and roof brick round out the total package.

Performance Highlights

FRC Global has all the products for your furnace needs. We offer working linings ranging from magnesia carbon to magnesia chrome. We also offer stadium brick, hearth bottom material and steep bank material. FRC Global can provide frit for hot-patching bottoms, tapholes, precast runners and door jambs, roof brick and all other specialties needed to complete the job. All are designed to provide optimum service in your specific operation with your existing practice. Our qualified engineers will help design a lining to fit your unique needs.

Degasser Refractories

Product Description

FRC Global has a full line of magnesia-chrome based products. Refractory linings from the snorkel to upper vessel can be specifically designed to meet your operating demands. Our goal is to provide maximum availability and long term economic viability.

Performance Highlights

- Completed ready to install snorkels
- High fired products based on fused magnesite-chrome grain
- Complete vessel designs to resist temperatures, abrasion and erosion
- High strength, excellent slag resistance and superior thermal shock resistance

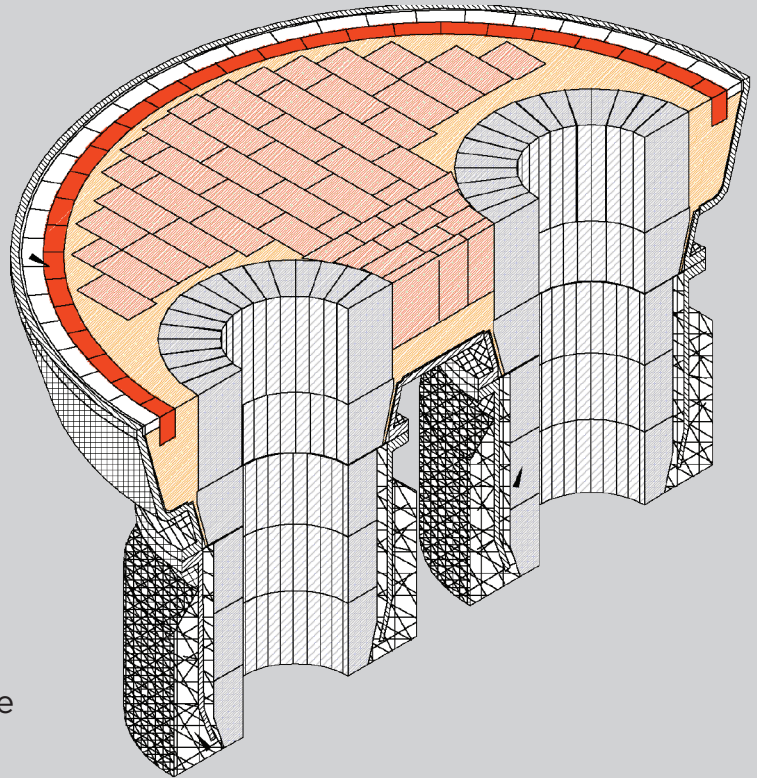



Slide Gates & Slide Gate Refractories

Product Description

FRC Global supplies slide gate refractory for a wide range of slide gate systems. Slide gate refractory is matched to your specific steel qualities. We are capable of complete turn-key installations of gate systems as well as the supply of consumables and parts.

Performance Highlights

- FRC Global is often able to do slide gate conversions without removing the level plate, which can create savings in time and money.
- We supply all accessory equipment if needed including hydraulic caster and ladle prep units.
- We offer pneumatic and hydraulic spring compression units at your discretion.
- We can provide your choice of either a direct drive or a bell crank system.
- FRC Global supplies hydraulic cylinders in either stationary or removable, depending on your specific needs.

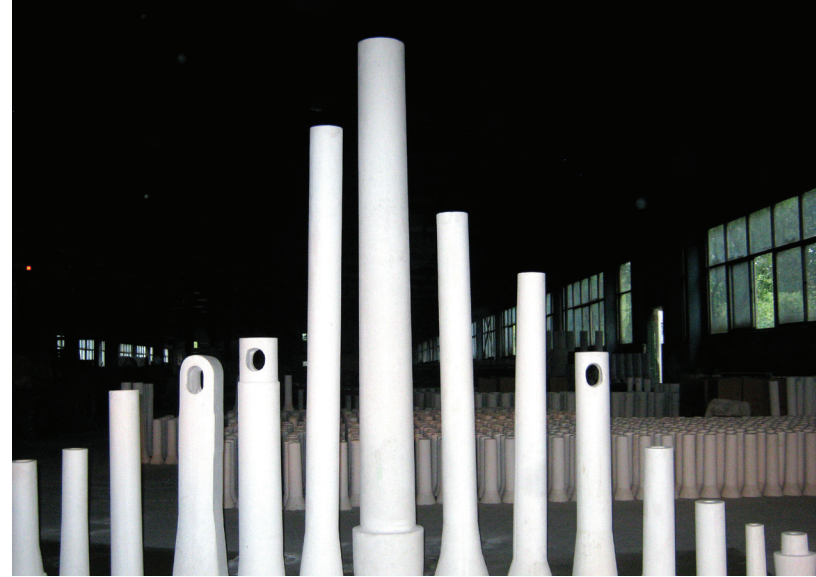

Shrouds, Nozzles & Stoppers

Product Description

Alumina-graphite: carbon-bonded, ISO-statically pressed single and multiple composition products used in both ferrous and non-ferrous applications. Typical uses are one-piece stopper rods, ladle shrouds, sub-entry nozzles and shrouds used for continuous casting of steel. All compositions are produced from the highest quality raw materials with strict process controls to ensure consistent high quality performance.

Fused silica: High purity fused silica grain begins the process for producing high-density, thermal shock-free fused silica products used in both ferrous and non-ferrous applications. The primary shape is ladle shrouds, but can be used for stoppers, sub-entry nozzles and shrouds along with other specified custom designs.

Performance Highlights

Experienced engineers and service personnel help provide cost effective designs and determine the material compositions for obtaining the greatest yield in steel production. All compositions are produced from the highest quality raw materials with strict manufacturing process controls resulting in consistent dependable product quality. Prior to shipment, FRC Global engineers are on location to perform quality audits on each lot of manufactured goods.

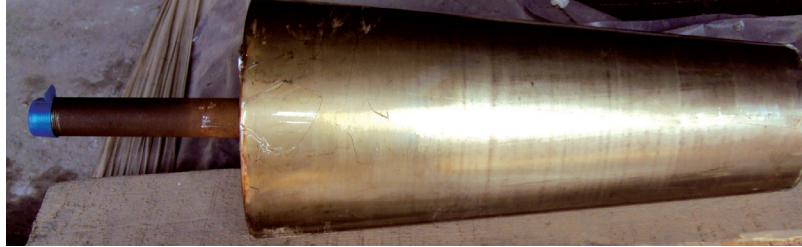

Gas Purging Plugs

Product Description

FRC Global carries both directional and non-directional plugs. They can be custom-made to any size, taper and flow rate. Every plug is tested before shipment for flow rate. FRC Global supports its plug sales with flow meters, control panels and pullers as needed.

Performance Highlights

- Stir plugs are equipped with two safety features:
 - A safety indicator is installed to the exact height the customer requests. This will let the customer know when it's time to remove the plug safely.
 - In the pipe is a chilling coil in case there is some steel penetration caused by over lancing.
- We supply training for our stir plugs. If a hot exchange system is used we will provide training on the system.
- We supply both a block and plug assembly or a hot exchange system, whichever the customer's needs might be.

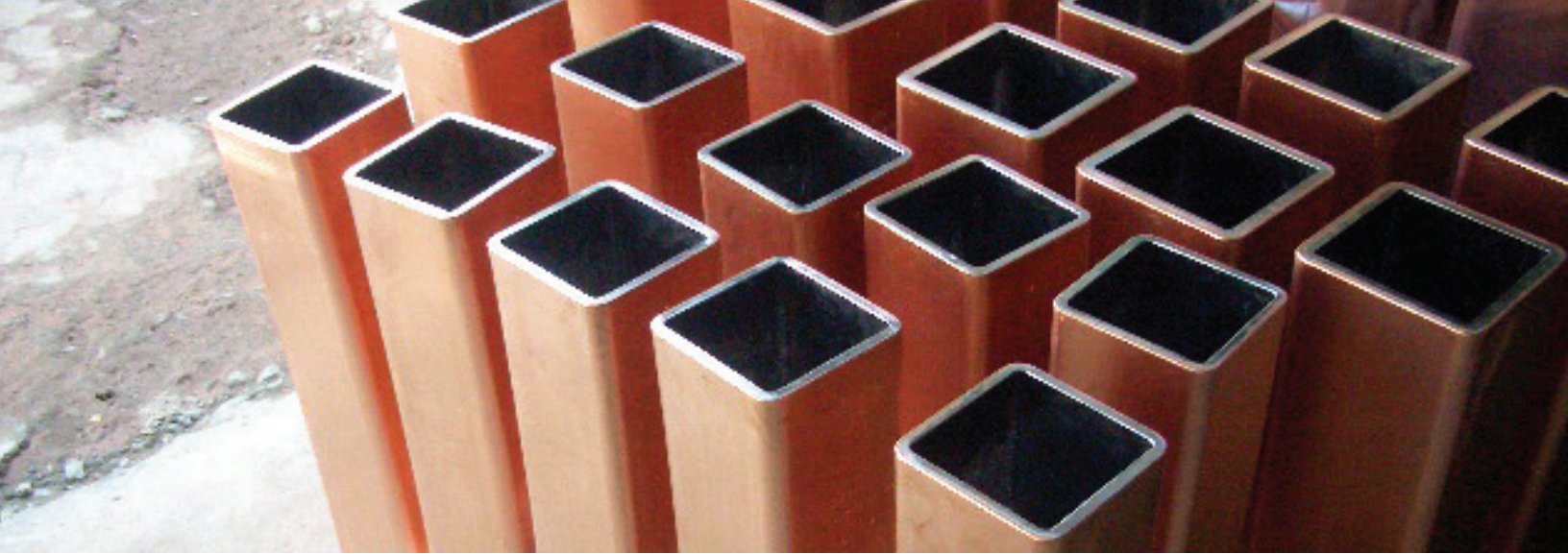

Copper Mold Tubes

Product Description

FRC Global offers custom copper mold tubes that are designed based on your specific needs. Our specialists are trained to determine the best composition, length and taper to maximize the performance of your caster and to optimize your quality. We also offer stainless steel water jackets and mold housings for all machines.

Performance Highlights

Molds for continuous casting of steel: Are you looking to increase production, solve quality issues or remove casting problems? FRC Global can help re-design and/or suggest mold tapers to suit the specific needs of your shop. We can supply square, round, near-net-shape, bloom and thin-strip molds. Additionally, we can supply stainless steel water jackets, mold housings, and foot roll assemblies.



Ingot Pouring Refractories

Product Description

We carry a complete line of high-quality products for the production of ingots. We offer hot top boards in insulating and exothermic materials that are tailored to your particular application. The hot topping system is completed with either topping powders or exothermic caps. Our Epic bottom pour tile is available in fireclay and alumina to help you meet your customers demands for clean steel. FRC Global can also supply all of your fiber needs, from basic blanket to custom made vacuum formed shrouds.

Performance Highlights

We know that one size will not fit all. FRC Global will work with you to customize our products to give you optimum performance. We have the experience and the product line to provide an engineered solution to help you exceed your goals.



Foundry Refractories

Product Description

Induction furnace linings are available in spinel (brick or dry vibrate), alumina (brick, dry vibrate and pre-cast), and magnesite-based (brick, ram and pre-cast) qualities. Electric arc furnace brick are available in silica, alumina, mag-chrome, mag-carbon, burned magnesite and burned dolomite. We offer ladle linings in ram, castable and brick in every quality (silica, alumina, spinel, alumina-chrome, alumina-carbon, alumina-magnesia-carbon, mag-chrome, dolomite, and mag-carbon).

Performance Highlights

We can supply almost any lining and all back-up linings for induction furnaces and electric arc furnaces. FRC Global offers refractory for any and all ladles. Designs include brick, dry-vibrate, castable, ram and combinations. Induction furnace linings are available in spinel (brick or dry vibrate), alumina (brick, dry vibrate and pre-cast), magnesite-based (brick, ram and pre-cast). Electric arc furnace linings are available in silica, alumina, mag-chrome, mag-carbon, burned magnesite and burned dolomite. Our custom-engineered refractory will provide you with optimum performance and reliability.

Graphite Boards

Graphite Boards are available in various dimensions to meet your thermal insulating needs. We utilize tar impregnation and small particle sizes to manufacture a high density, high strength product with a low CTE.

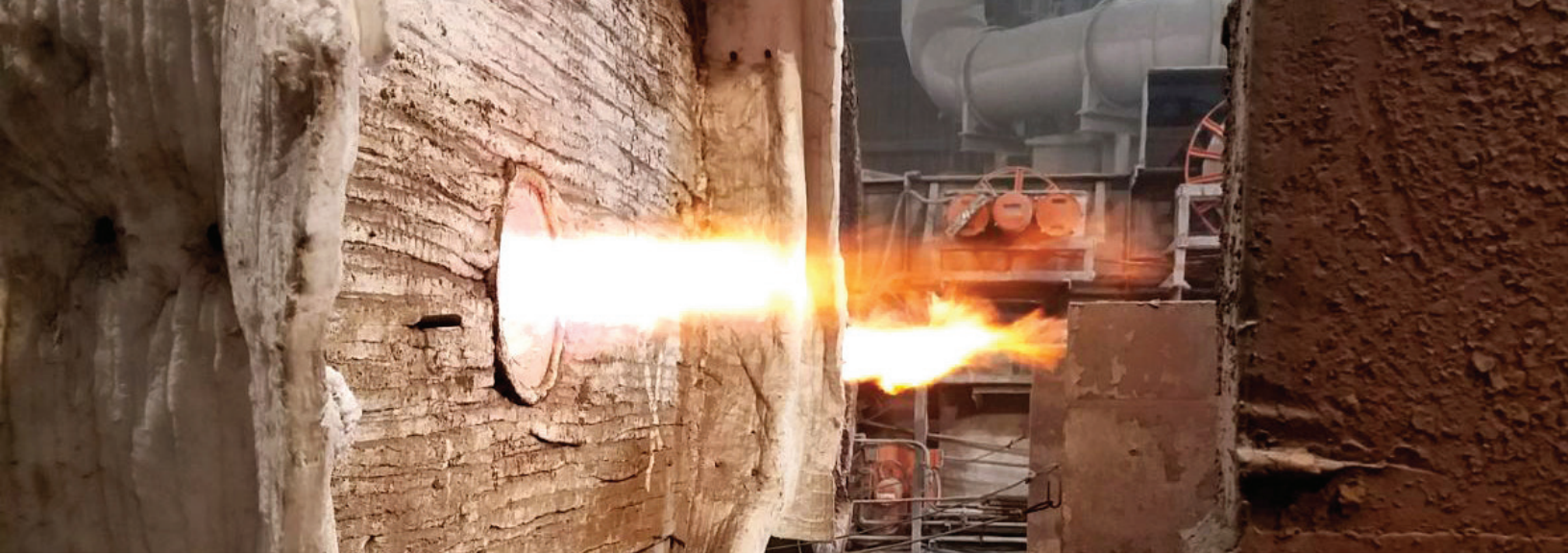

Ceramic Fiber

Product Description

Ceramic fiber is an excellent insulator and has uses to fill gaps, or when compressed into modules, can be structural in walls and floors of some furnaces. Ceramic fiber is available in various melting points and chemistries, as well as different densities. FRC is happy to provide the right fiber in the length, width and density you desire.

Performance Highlights

We can supply ceramic fiber blanket, board, textile, paper, cotton, felt, module, heteromorphism, fiber spray pouring material, and other fiber product to fit your needs. 2300° 6Lb. and 8Lb. 2600° 6Lb. and 8Lb. are readily available and all fiber products can be sent to your shop either in boxes or wrapped plastic bags. Boxes ship with 20 per pallet. A container will carry 21 pallets and 470 rolls. Wrapped plastic bags ship directly with 600 rolls in a container.

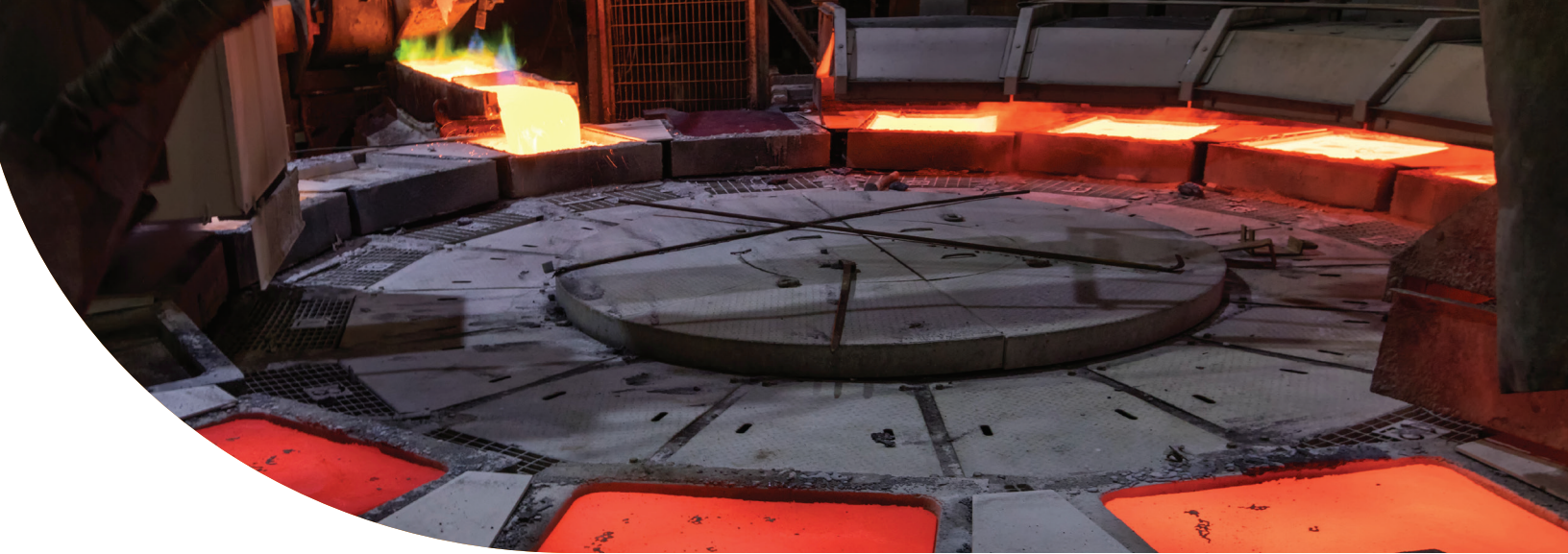

Copper, Nickel, and Lead Refractories

Product Description

FRC Global carries a full line of high-quality products for the primary and secondary production of non-ferrous metals.

For copper, nickel and lead, we offer magnesite-chrome brick in many different formulations. From direct-bonded to fully re-bonded, and everything in between, we supply brick made only from 100% virgin materials. Supplementing the brick line is a full catalog of specialties including mortars, castables, plastics and rams.

Performance Highlights

FRC Global has all of the products required for your smelting needs. We offer magnesia-chrome working lining bricks, insulators, back-up linings, anchors and specialties. All our products are designed to provide optimum service in your specific operation with your existing practice. By varying raw materials, firing schedules and post-firing treatments like salt impregnation, we can engineer a solution for you.



Cored Wire & Alloys

Cored Wire

Product Description

We are dedicated to supplying high quality and cost effective cored wire. Our cored wire provides the highest recovery rate, and increases productivity in the secondary metallurgical process.

Performance Highlights

Our cored wire solution is an ideal choice for the steel industry. It comes in diameter sizes of 9, 13 and 16 millimeters. We have a modern manufacturing process which provides consistent core densities offering an accurate core to steel percentage. The ratio of core to steel provides instant, exact metallurgy when the core is melted and the impurities are then removed. Our packaging can meet all your requirements with coil packaged in either horizontal or vertical axis's.

Alloys

Product Description

FRC Global can supply your common alloy needs. Our high-quality alloys are priced competitively, yet are fully guaranteed.

Performance Highlights

We offer a variety of commodity alloys at different carbon levels to fit your target chemistry.

- Ferrosilicon
- Ferrochrome
- Ferromanganese
- Aluminum notch bar and ingot

Why FRC for you alloy needs?

We do much more than just alloys, and therefore focus on being competitive by providing the highest value possible. By offering only high-quality, high-performance products at aggressive price points, we pass that value on to you.



Sand Products

Product Description

FRC Global offers a variety of sand products to fit your needs.

Magfill is a synthetic forsterite calcined at 1450 °C (2700 °F). The uses for magfill include EBT taphole fill, ladle nozzle fill, tundish insulation, and EAF stadium backfill. It is less dense than green olivine, it is more insulating and has no organics and no gas evolution. Due to the calcining and the mineralogy, there is almost no free silica.

Flosan is our ladle nozzle fill and it has a range of chemistries for various grades, heat sizes, processes and bore configurations. From pure quartz to pure zirconia and chromite blends of each, FRC Global will develop a blend for your unique application.

Ladle mag is our ladle backfill and is a synthetic forsterite with or without a

binder. It has little or no free silica and is almost dust free due to top and bottom size screening. It is free flowing to minimize effort and time during installation. It sticks to the working lining, not the safety lining. It will flow freely from a hopper. Handling equipment is inexpensive and is very easy to maintain.

Performance Highlights

FRC Global products are based solely on virgin raw materials. No reclaimed sand or minerals is used in any of our products. Sand blends are produced according to our proprietary formula. We have a focus on relative cost, particle packing and maximizing performance. Custom formulations are possible at no additional charge to match the unique characteristics of your process. We provide a trial evaluation and continual monitoring of product performance. Custom equipment is available if required for material handling and/or placement.



Iron Making and Taphole Clay

Description

FRC global has the capability to supply any and all products needed for your ironmaking operation. From consumables to repairs to relines, we can do it all. We also offer custom shapes and compositions to suit your particular needs. From engineered clays to precast shapes, we have the solution.

Performance Highlights

- Taphole clay is designed for your specific furnace
- Environmentally friendly—ultra low PAH —no special labeling
- Manufactured in a modern, quality controlled facility



Combustion Systems

Product Description

The Thermal Kinetic Energizer is a revolutionary system used in industrial heating to replace conventional gas burners. The TKE-HTT™ uses a small amount of natural gas to power a stream of molecules traveling at 220m/second resulting in the direct transfer of kinetic energy to heat. The energy transfer produces uniform heat within the vessel, work piece or heat exchange system while reducing the harmful emissions associated with a conventional burner system.

Performance Highlights

This proprietary TKE-HTT™ technology developed by Carl Mörsner applies to all industries using the following direct-fired, forced-draft heating apparatus:

- Ladle Preheaters
- Ladle Dryers
- Tundish Preheaters
- Stationary Forging and Reheating Furnaces
- Torpedo Cars

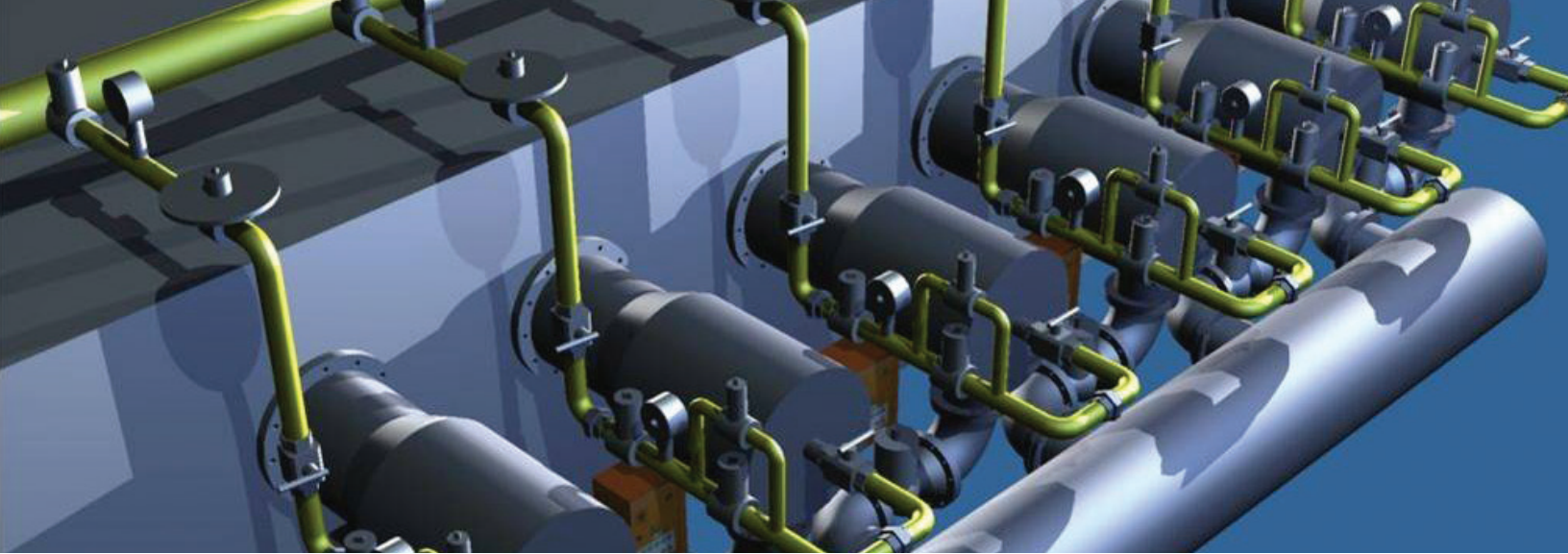

Benefits of installing the TKE-HTT™

- A reduction in fuel consumption of 50% or greater.
- Overall reduction of emissions due to reduced fuel consumption.
- A reduction in heat processing times.
- Lower temperatures may yield the same results.
- Near Zero Delta T between environment and the vessel, charge or work piece.
- Temperature uniformity.
- Elimination of thermal stress, reducing cracking and deformation of the work piece.
- Faster ramp up time.
- An increase in heating system reliability

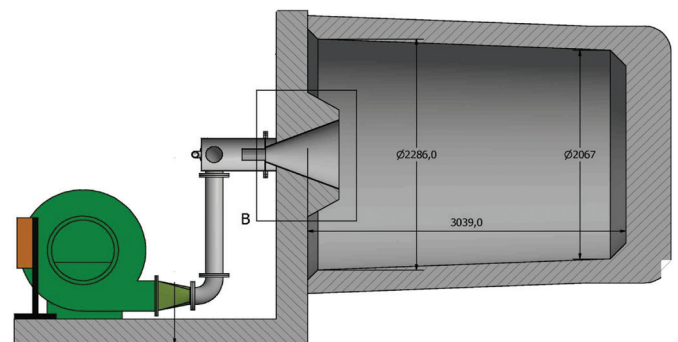
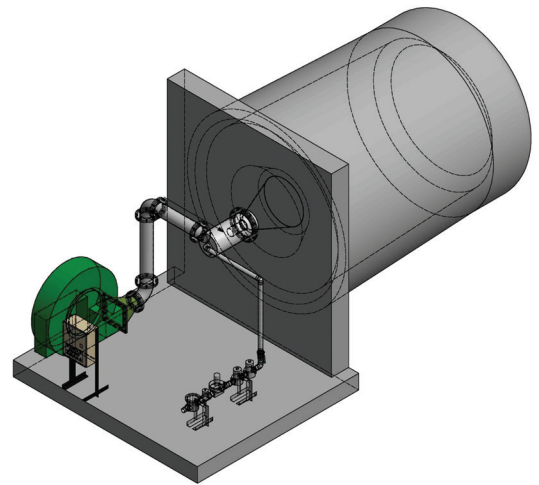



Graphite Electrodes

Product Description

FRC Global is a world-leading supplier of high quality graphite electrodes. Our premium electrodes are produced to meet modern steel industry consumption needs by providing a combination of reliability, performance and cost effectiveness. FRC Global is committed to quality throughout the manufacturing operations so we only use the best premium needle coke and other premium petroleum raw material. Our rigid quality assurance standards allows us to control all critical process variables.

Performance Highlights

We provide a wide range of technical support services that are designed to help you achieve even higher levels of productivity and performance. Among the services that our FRC Global Tech Team provides is a proven method of evaluating your EAF and LMF. We couple this evaluation with an extended measurement of electrical and operating parameters using modern technical monitoring equipment to provide you with maximum operating efficiency solutions.

Working Alongside You

FRC offers advisory and consultation support for your project at any stage of the process: site viability, process and operations, technical assistance to engineering teams, equipment selection, project logistics, assistance training and supervising project personnel. FRC also provides technical support, training and supervision to project personnel in the following areas: electric arc furnace, ladle metallurgy furnace, and continuous caster.





High Temp Innovation

United States

1000 N. West Street, Suite 1200 #3008
Wilmington, DE 19801

Canada

Montreal, Quebec

South America

Cali, Colombia
Phone: 011-57-310-826-2701

Asia

Dalian, China

1.800.609.5711

FRCglobal.com

